

# Ni-Cd Battery Individual Data Sheets

## Type: D-SC1500H

### Specifications

Nominal voltage		1.2V	
Capacity <sup>1</sup>		0.2C Discharge	1C Discharge
	Minimum	1500mAh <sup>2</sup>	1350mAh
	Typical <sup>3</sup>	1650mAh	1500mAh
Dimensions	Diameter	mm	inch
		23.0 <sup>0</sup> <sub>-1.0</sub>	0.906 <sup>0</sup> <sub>-0.039</sub>
	Height	43.0 <sup>0</sup> <sub>-1.0</sub>	1.693 <sup>0</sup> <sub>-0.039</sub>
Weight <sup>4</sup>	Grams	Ounces	
	46	1.62	
Internal impedance <sup>4</sup> at 1000Hz.		8mΩ (After charge)	
Charge	Standard	150mA(0.1C) X 15hrs	
	Trickle	75mA(0.05C) X 48hrs	
Ambient temperature	Charge	°C	°F
		Standard	0°C to 60°C
	Trickle	0°C to 60°C	32°F to 140°F
	Discharge	-20°C to 70°C	-4°F to 158°F
Storage	-20°C to 45°C	-4°F to 113°F	

### Dimensions(with tube)

(mm)

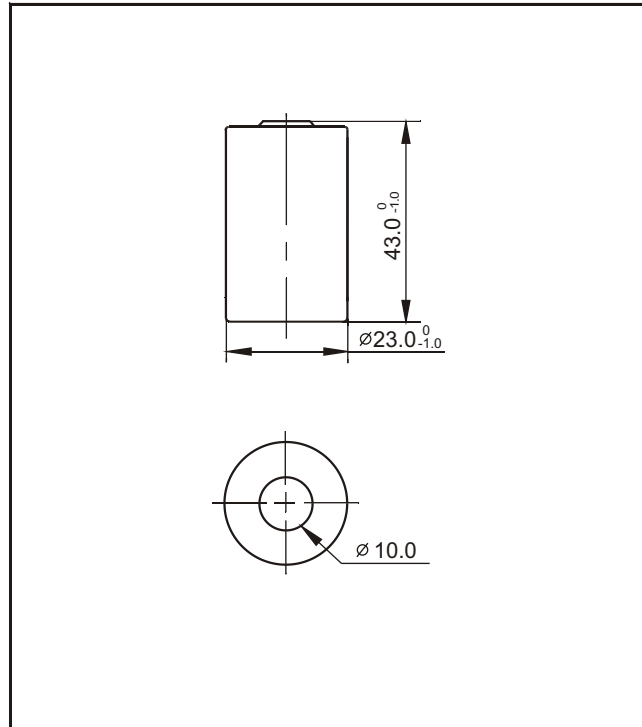

Note:

1. After charging at 0.1C for 15 hours.
2. Nominal capacity, rated at 0.2C, 20°C
3. Average capacity. For reference only.
4. Weight and internal impedance are for reference.

### Typical characteristics

#### Standard charge characteristics

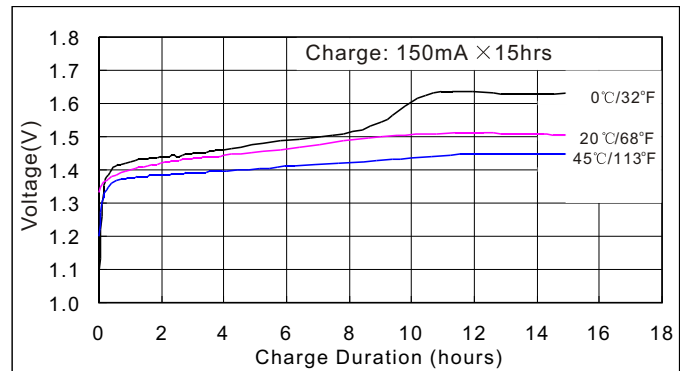

#### Trickle charge characteristics

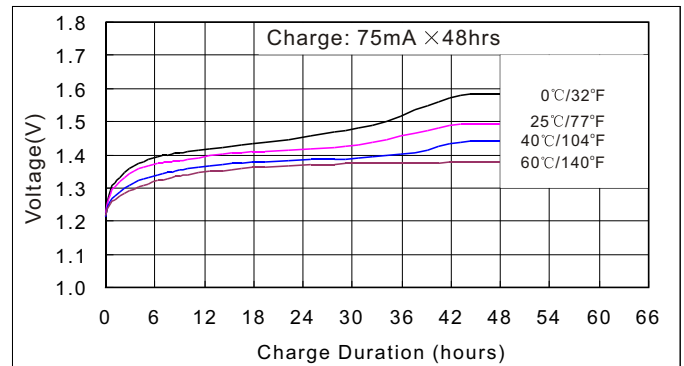

#### Discharge characteristics

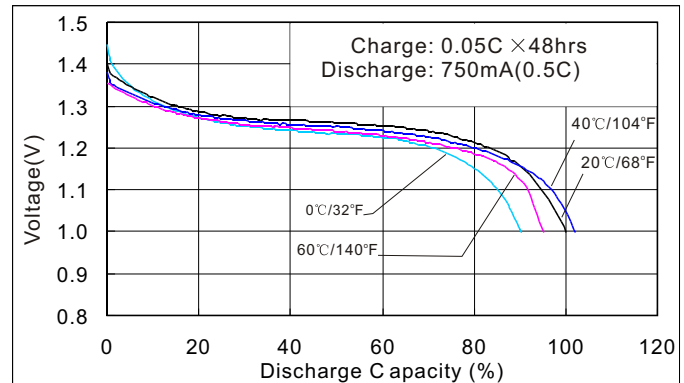

#### Charge Efficiency

